

2000 EV series

For artisan bakers

Up to 160 kg of dough*

The world reference for the production of:

- Speciality bread
- Viennese pastry
- Short pastry



- Clear bowl cover with access door
- Stainless steel bowl to fully comply with health regulations



MEW-EV version



Bowl drive by roller for consistent and accurately repeatable recipes

For more information:



Video



Commercial documentation

* Maximum dough capacity. Example for an average hydration rate of 60%. More information here.

Fork mixers with fixed bowl 2170 EV

General Features



- Mixer with fixed stainless steel bowl
- Bowl with variable speed
- 2 tool speeds
- 2 motors: bowl and tool
- Clear bowl cover with access door
- Manual head lifting
- 400 V - 3 phases + Earth - 50Hz (any other specific voltage available and free of charge providing that it is technically possible)
- Power: 6 kW
- Intensity: 14 A
- IP 54



2170 SEW-EV Code:
Code:

B50201904 (Phebus arm)
B50201904-0001 (Rex arm)

- 1 sonatan timer



Phebus arm



Rex arm

2170 MEW-EV Code:
Code:

B50201905 (Phebus arm)
B50201905-0001 (Rex arm)

- 2 programmable timers

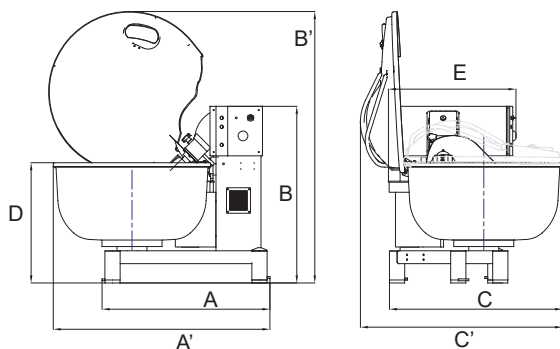

Capacity motorized bowl	Mixers 2170 EV
Total bowl volume (l)	170
Max. dough capacity (kg)*	80
Weight (kg)	447
Dimensions (mm)	
Width (A)	1035
Total width (A')	1260
Height closed (B)	1180
Height open (B')	1665
Depth (C)	995
Total depth (C')	1110
Bowl height (D)	760
Frame width (E)	800
Bowl diameter Ø	802

*Example for an average hydration rate of 60%.
More information here.

See conditions on page 5

Important : accessory orders that are disconnected from a machine order will be processed by our after-sales department.